

NOTES:

1. RESILIENT-WEDGE GATE VALVES TO BE USED FOR ALL APPLICATIONS 4-INCH THROUGH 12-INCH. APPROVED RESILIENT-WEDGE VALVES AS FOLLOWS:
KENNEDY (KEN-SEAL 11) #4561
MUELLER #A-2362
AFC SERIES 2500
CLOW #F6102
AVK SERIES #25
2. AWWA C504 BUTTERFLY VALVES TO BE USED FOR ALL APPLICATIONS 16-INCH AND GREATER. APPROVED BUTTERFLY VALVES AS FOLLOWS:
MULLER
PRATT
3. #1-RT BROOKS BOX WITH CAST IRON RING AND COVER MARKED "WATER" REQUIRED FOR USE IN CONCRETE PAVEMENT.
4. VALVE BOX ASSEMBLY IN LANDSCAPE AREA SHALL BE BROOKS #1-RT SET ABOVE FLOOD RIM ELEVATION.
J & R
H & C CONCRETE
5. VALVE OPERATOR EXTENSION REQUIRED WHEN TOP OF NUT EXCEEDS A DEPTH OF 5 FEET FROM FINISHED SURFACE, SEE STD. DWG. NO. 116.
6. WRAP PIPE & BOLTS WITH 20 MILL PLASTIC.

REV.	DESCRIPTION	DATE	APP'D

Cucamonga Valley Water District

VALVE AND BOX ASSEMBLY

Cucamonga Valley Water District
ENGINEERING DEPARTMENT
10440 ASHFORD STREET, RANCHO CUCAMONGA, CA 91729
(909) 987-2591

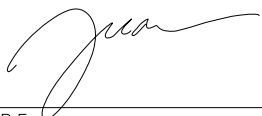
APPROVED BY: 

TUAN TRUONG, P.E.,
ENGINEERING MANAGER

4-17-25
DATE

STD. DWG.
115
SHT. 1 OF 1

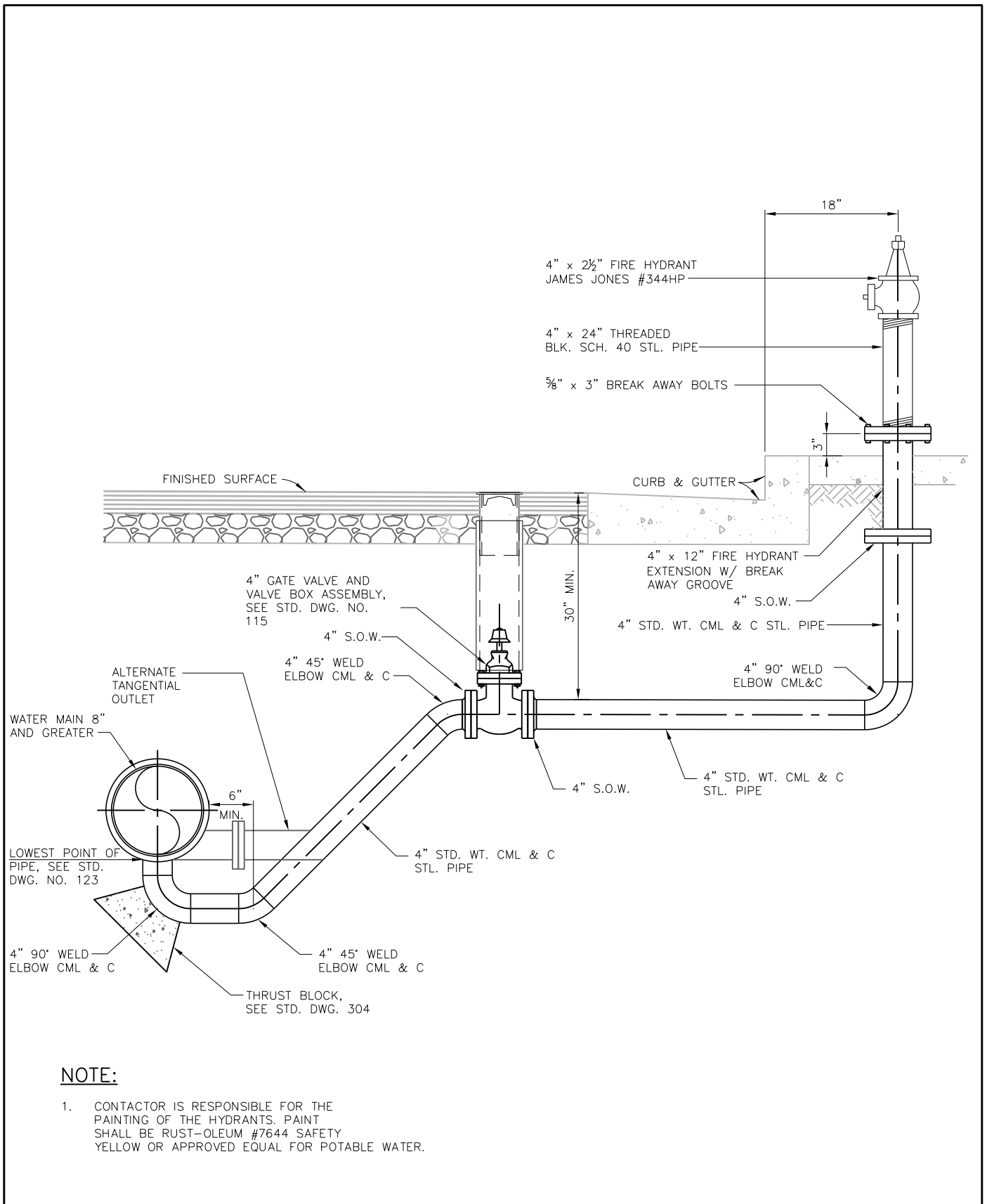

NOTE:

- CONTACTOR IS RESPONSIBLE FOR THE PAINTING OF THE HYDRANTS. PAINT SHALL BE RUST-OLEUM #7644 SAFETY YELLOW OR APPROVED EQUAL FOR POTABLE WATER.

REV.	DESCRIPTION	DATE	APP'D

Cucamonga Valley Water District

BLOW OFF ASSEMBLY 4 INCH AND ABOVE

Cucamonga Valley Water District
 ENGINEERING DEPARTMENT
 10440 ASHFORD STREET, RANCHO CUCAMONGA, CA 91729
 (909) 987-2591

APPROVED BY:

TUAN TRUONG, P.E.,
 ENGINEERING MANAGER

4-17-25
 DATE

STD. DWG.

119

SHT. 1 OF 1

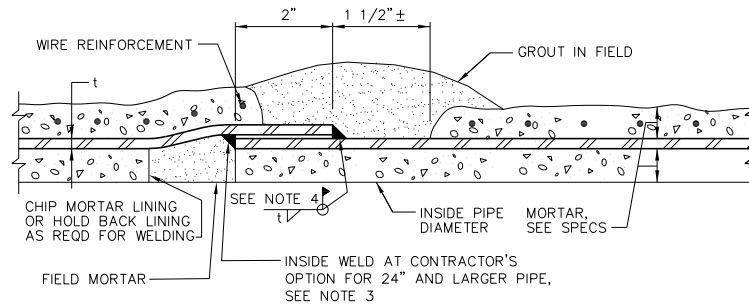

SINGLE / DOUBLE LAP WELDED JOINT

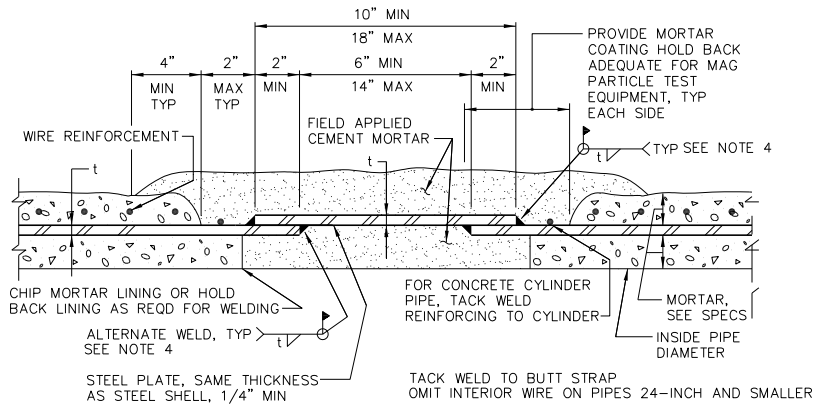

BUTT STRAP JOINT

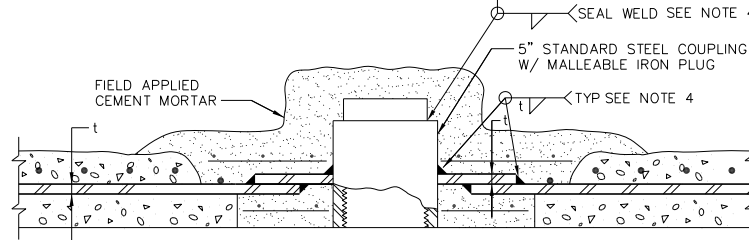

TYPICAL HANDHOLE FOR BUTT STRAP JOINT

MLCSP JOINT NOTES

1. HANDHOLE REQUIRED ON PIPE SMALLER THAN 24" DIAMETER.
2. PROVIDE ADEQUATE HOLDBACK OF CEMENT MORTAR LINING AND COATING FOR WELDING AND TESTING OF WELDS.
3. WHERE DOUBLE LAP WELD IS SHOWN ON THE DRAWINGS, WELD INSIDE AND OUTSIDE.
4. ALL WELDING SHALL BE 2 PASS MINIMUM.
5. ON FITTINGS, CONTRACTOR SHALL USE WELD BELL FITTINGS OR WEDDING BANDS.
6. PIPE JOINT DIAPERS MAY BE USED WHERE APPLICABLE, PER THE APPROVAL OF THE CVWD INSPECTOR.
7. HAMMER AND CHISEL SHALL BE USED TO REMOVE CEMENT COATING. POWER CUT-OFFS SAWS SHALL NOT BE USED TO REMOVE COATING. SCOURED OR DAMAGED STEEL SHALL BE REJECTED.
8. NSF-61 CERTIFIED GROUT SHALL BE USED FOR INTERIOR JOINT REPAIR

REV.	DESCRIPTION	DATE	APP'D

Cucamonga Valley Water District

MORTAR LINED & COATED STEELL PIPE JOINT DETAIL



**Cucamonga Valley
Water District**

ENGINEERING DEPARTMENT
10440 ASHFORD STREET, RANCHO CUCAMONGA, CA 91729
(909) 987-2591

APPROVED BY:

TUAN TRUONG, P.E.,
ENGINEERING MANAGER

STD. DWG.

126

4-17-25
DATE

SHT. 1 OF 1

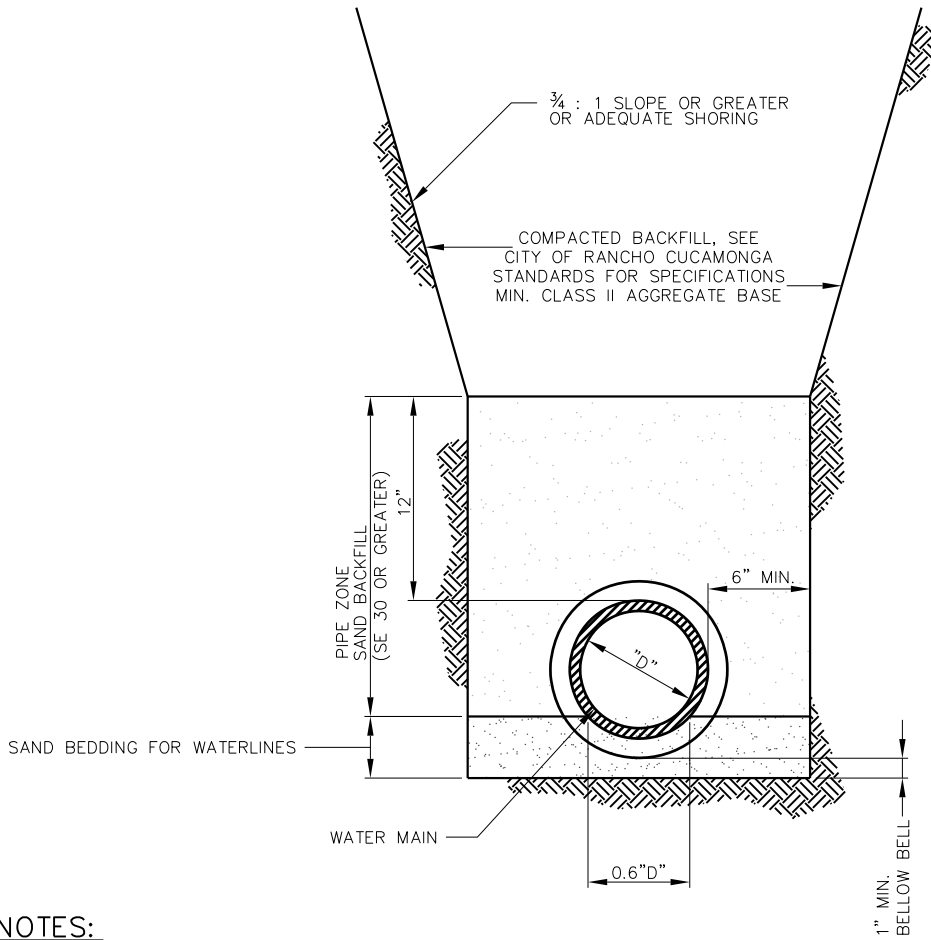

NOTES:

1. TRENCH WIDTH SHALL BE CONTROLLED TO TOP OF PIPE ZONE.
2. TRENCH DEPTHS OF GREATER THAN 5' SHALL HAVE ADEQUATE SHORING.
3. COMPACTION SHALL BE 95% IN ALL ZONES UNLESS OTHERWISE SPECIFIED.
4. TRENCH STABILITY TO CONFORM TO CAL-OSHA REQUIREMENTS.

REV.	DESCRIPTION	DATE	APP'D

Cucamonga Valley Water District
WATER TYPICAL TRENCH SECTION

Cucamonga Valley Water District
 ENGINEERING DEPARTMENT
 10440 ASHFORD STREET, RANCHO CUCAMONGA, CA 91729
 (909) 987-2591

APPROVED BY:

 TUAN TRUONG, P.E.,
 ENGINEERING MANAGER

4-17-25
 DATE

STD. DWG.

301-A

SHT. 1 OF 2

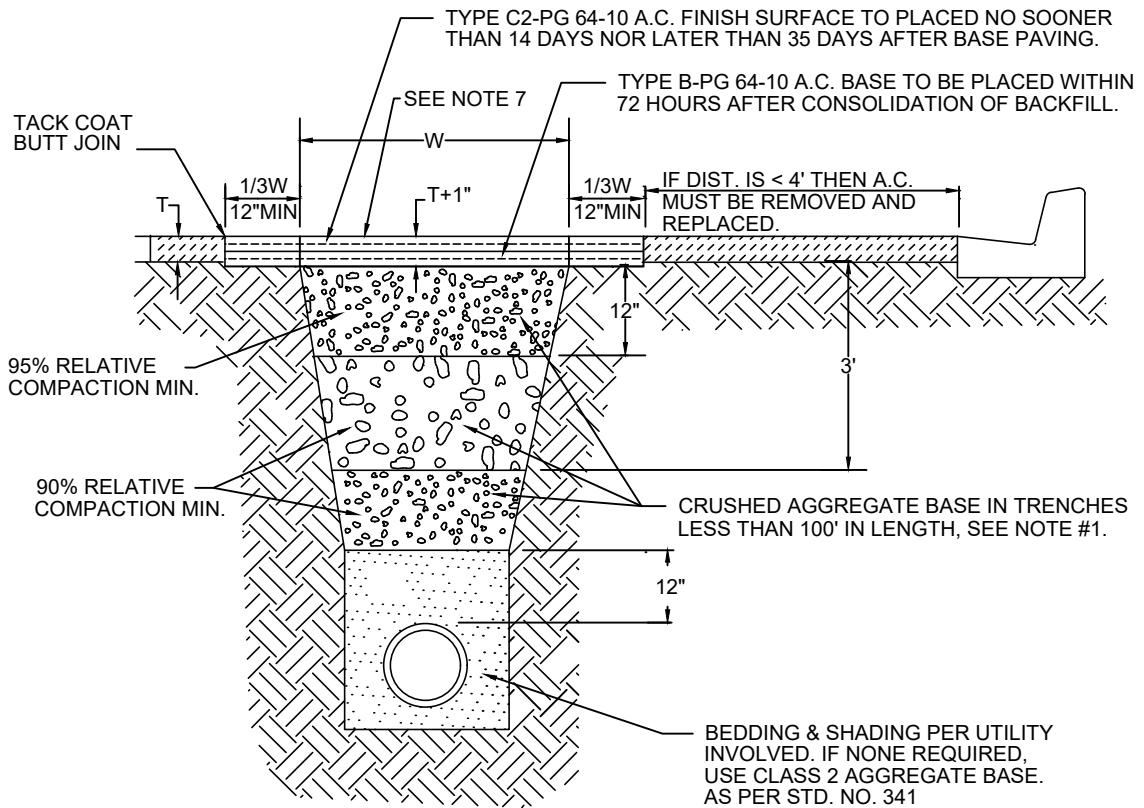

NOTES:

1. ALL TRENCHES 100' IN LENGTH OR LARGER SHALL BE BACKFILLED AND CONSOLIDATED PER SECTION 306-1.3.1 THRU 306-1.3.4 OF THE STANDARD SPECIFICATIONS.
2. SPREAD BOXES MAY BE EMPLOYED ON TRENCH PAVING JOBS LESS THAN 500 LINEAR FEET.
3. ALL JOINTS SHALL BE VERTICAL BUTT JOINTS, LAP OR FEATHERED JOINTS ARE NOT ACCEPTABLE.
4. UNLESS OTHERWISE INSTRUCTED BY THE CITY ENGINEER, TRENCH PATCH SHALL BE STRAIGHT GRADE ACROSS WIDTH, AND SHALL NOT BE CROWDED AT CENTER.
5. PRIOR TO PLACEMENT OF A.C. PAVEMENT, EDGE SHALL BE CUT TO A CLEAN VERTICAL AND STRAIGHT EDGE WITH TACK COAT ON FACE OF CUT.
6. THE ENTIRE TRAVELED LANE, 12' MIN. SHALL BE OVERLAYED WITH 0.10' MIN. C2-PG 64-10 A.C. USING A SELF PROPELLED PAVING MACHINE (BARBER, GREEN, BLAW KNOX OR EQUAL) FOR ALL TRENCHES 500' IN LENGTH OR LONGER.
7. PERMANENT A.C. PATH, WHICH SHALL BE A MINIMUM 0.25' THICK OR 0.10' THICKER THAN EXISTING - WHICHEVER IS GREATER - AS DIRECTED BY THE CITY REPRESENTATIVE IN THE FIELD.



CITY OF RANCHO CUCAMONGA

TRENCH REPAIR

USE WITH STANDARD SPECIFICATIONS FOR PUBLIC WORKS CONSTRUCTION

APPROVED BY: JASON C. WELFAY 5/21/2019 R.C.E. 67514
 CITY ENGINEER DATE

STD. PLAN NO.
120

SHEET
1 OF 2

DATE OF
LAST REVISION
05/20/2019

TEMPORARY STEEL PLATE BRIDGING-WITH A NON-SKID SURFACE

WHEN BACKFILLING OPERATIONS OF AN EXCAVATION IN THE ROADWAY INCLUDING BIKE LANES AND PARKING STRIP, WHETHER TRANSVERSE OR LONGITUDINAL, CANNOT BE PROPERLY COMPLETED WITHIN A WORK DAY, STEEL PLATE BRIDGING WITH A NON-SKID SURFACE AND SHORING SHALL BE REQUIRED TO PRESERVE UNOBSTRUCTED TRAFFIC FLOW. IN SUCH CASES, THE FOLLOWING CONDITIONS SHALL APPLY:

1. STEEL PLATES USED FOR BRIDGING MUST EXTEND A MINIMUM OF 12" BEYOND THE EDGES OF THE TRENCH.
2. STEEL PLATE BRIDGING SHALL BE INSTALLED TO OPERATE WITH MINIMUM NOISE.
3. THE TRENCH SHALL BE ADEQUATELY SHORED TO SUPPORT THE BRIDGING AND TRAFFIC LOADS.
4. TEMPORARY PAVING WITH COLD ASPHALT CONCRETE SHALL BE USED TO FEATHER THE EDGES OF THE PLATES (10:1/H:V MIN), IF PLATE INSTALLATION BY METHOD (2) DESCRIBED BELOW, IS USED.
5. BRIDGING SHALL BE SECURED AGAINST DISPLACEMENT BY USING ADJUSTABLE CLEATS, SHIMS, OR OTHER DEVICES.
6. "ROAD CONSTRUCTION AHEAD" (W20-1) SIGN SHALL BE USED 1,000' IN ADVANCE OF STEEL PLATES.
7. "STEEL PLATES AHEAD" (TYPE P) SIGN SHALL BE PLACED 500' IN ADVANCE OF STEEL PLATES.

AS REQUIRED BY THE CITY, STEEL PLATE BRIDGING AND SHORING SHALL BE INSTALLED USING EITHER METHOD (1) OR (2):

METHOD 1 FOR SPEEDS 45 MPH OR GREATER:

- A. THE PAVEMENT SHALL BE COLD PLANED TO A DEPTH EQUAL TO THE THICKNESS OF THE PLATE AND TO A WIDTH AND LENGTH EQUAL TO THE DIMENSIONS OF THE PLATE.
- B. APPROACH PLATE(S) AND ENDING PLATE (IF LONGITUDINAL PLACEMENT) SHALL BE ATTACHED TO THE ROADWAY BY A MINIMUM OF TWO (2) DOWELS PRE-DRILLED INTO THE CORNERS OF THE PLATE AND DRILLED 2" INTO THE PAVEMENT. SUBSEQUENT PLATES ARE TO BE BUTTED AND TACK WELDED TO EACH OTHER.

METHOD 2 FOR SPEEDS LESS THAN 45 MPH:

- A. APPROACH PLATE(S) AND ENDING PLATE (IF LONGITUDINAL PLACEMENT) SHALL BE ATTACHED TO THE ROADWAY BY A MINIMUM OF TWO (2) DOWELS PRE-DRILLED INTO THE CORNERS OF THE PLATE AND DRILLED 2" INTO THE PAVEMENT.
- B. SUBSEQUENT PLATES ARE TO BE BUTTED AND TACK WELDED TO EACH OTHER.
- C. FINE GRADED ASPHALT CONCRETE SHALL BE COMPACTED TO FORM RAMPS, MAXIMUM SLOPE 8.5% WITH A MINIMUM 12" TAPER TO COVER ALL EDGES OF THE STEEL PLATES.
- D. WHEN STEEL PLATES ARE REMOVED, THE DOWEL HOLES IN THE PAVEMENT SHALL BE BACKFILLED WITH EITHER GRADED FINES OF ASPHALT CONCRETE MIX, CONCRETE SLURRY, EPOXY OR AN EQUIVALENT THAT IS SATISFACTORY TO THE CITY'S REPRESENTATIVE.

THE CONTRACTOR IS RESPONSIBLE FOR MAINTENANCE OF THE STEEL PLATES, SHORING, ASPHALT CONCRETE RAMPS, AND ENSURING THAT THEY MEET MINIMUM SPECIFICATIONS. UNLESS NOTED OR APPROVED OTHERWISE, STEEL PLATE BRIDGING SHALL NOT EXCEED FOUR (4) CONSECUTIVE WORKING DAYS IN ANY GIVEN WEEK AND SHOULD NOT BE LEFT THROUGH THE WEEKEND. BACKFILLING OF EXCAVATIONS SHALL BE COVERED WITH A MINIMUM 3" TEMPORARY LAYER OF COLD ASPHALT CONCRETE. THE FOLLOWING TABLE SHOWS THE MINIMUM THICKNESS OF STEEL PLATE BRIDGING REQUIRED FOR A GIVEN TRENCH WIDTH (A-36 GRADE STEEL, DESIGNED FOR HS20-44 TRUCK LOADING).

<u>TRENCH WIDTH</u>	<u>MINIMUM PLATE THICKNESS</u>
10 INCHES	1/2 INCH
1 FOOT 11 INCHES	3/4 INCH
2 FEET 7 INCHES	7/8 INCH
3 FEET 5 INCHES	1 INCH
5 FEET 3 INCHES	1 3/4 INCH



CITY OF RANCHO CUCAMONGA

TRENCH REPAIR

USE WITH STANDARD SPECIFICATIONS FOR PUBLIC WORKS CONSTRUCTION

APPROVED BY: Jason C. Welday 5/21/2019 R.C.E. 67514
 JASON C. WELDAY DATE
 CITY ENGINEER

STD. PLAN NO.
120

SHEET
2 OF 2

DATE OF
LAST REVISION
05/20/2019